

SECTION 'A-A' ISO VIEW

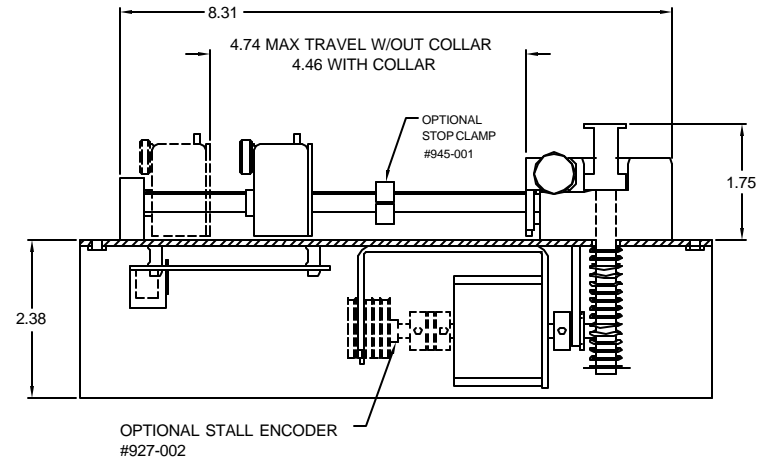
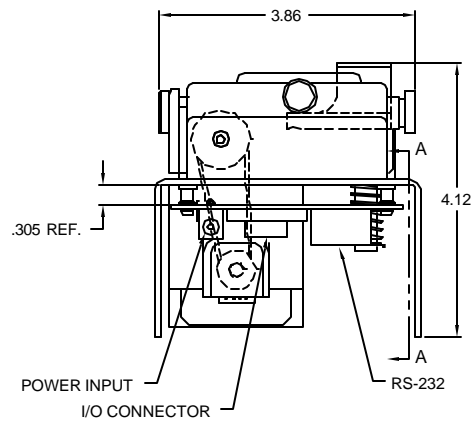
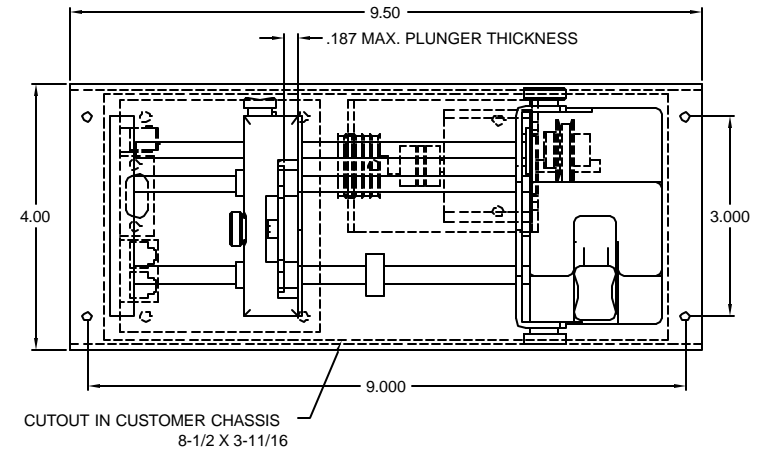

SECTION 'A-A'

New Era Pump Systems, Inc.
www.SyringePump.com

631-249-1392
info@syringepump.com

Title

OEM Syringe Pump

Part No.

Model NE-5xx

Date 5/7/08

Rev. A

Pump Overall Dimensions